

Inch Series Button Head Socket Cap Screws

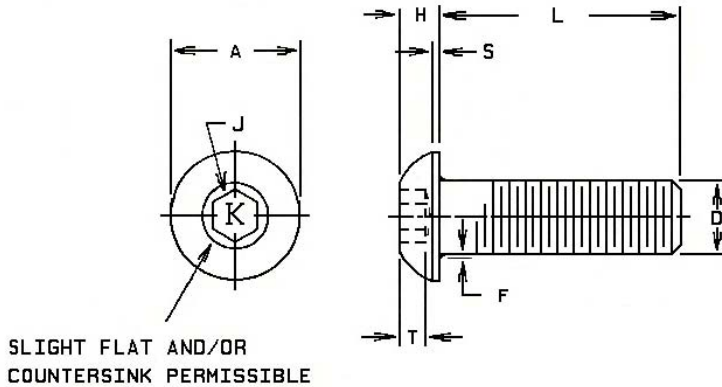

Nominal Size	D	A		H		S	M	J		T
	Basic Screw Diameter	Head Diameter Max. Min.		Head Height Max. Min.				Head Side Height Ref.	Spline Socket Size Nominal	
#2	0.0860	0.164	0.154	0.046	0.038	0.010	0.060	0.050		0.028
#3	0.0990	0.188	0.176	0.052	0.044	0.010	0.072	1/16	0.062	0.035
#4	0.1120	0.213	0.201	0.059	0.051	0.015	0.072	1/16	0.062	0.035
#5	0.1250	0.238	0.226	0.066	0.058	0.015	0.096	5/64	0.078	0.044
#6	0.1380	0.262	0.250	0.073	0.063	0.015	0.096	5/64	0.078	0.044
#8	0.1640	0.312	0.298	0.087	0.077	0.015	0.111	3/32	0.094	0.052
#10	0.1900	0.361	0.347	0.101	0.091	0.020	0.145	1/8	0.125	0.070
1/4	0.2500	0.437	0.419	0.132	0.122	0.031	0.183	5/32	0.156	0.087
5/16	0.3125	0.547	0.527	0.166	0.152	0.031	0.216	3/16	0.188	0.094
3/8	0.3750	0.656	0.636	0.199	0.185	0.031	0.251	7/32	0.219	0.122
1/2	0.5000	0.875	0.851	0.265	0.245	0.046	0.372	5/16	0.312	0.175
5/8	0.6250	1.000	0.970	0.331	0.311	0.062	0.454	3/8	0.375	0.210

Nominal Size	F		L
	Fillet Extension Max. Min.		
#2	0.010	0.005	1/2
#3	0.010	0.005	1/2
#4	0.010	0.005	1/2
#5	0.010	0.005	1/2
#6	0.010	0.005	5/8
#8	0.015	0.010	3/4
#10	0.015	0.010	1
1/4	0.020	0.015	1
5/16	0.020	0.015	1
3/8	0.020	0.015	1 1/4
1/2	0.030	0.020	2
5/8	0.030	0.020	2

Applicable Standards: ASME B18.3 and ASTM F835. Hardness: Rc39-44. Tensile Strength: 145,000 psi minimum 1/2 inch and smaller. Hardness Rc 37-44 and tensile strength 135,000 psi minimum over 1/2 inch diameter. Data is for full size product. Minimum tensile strength is 180 ksi 1/2 inch diameter and below, 170 ksi over 1/2 inch diameter.

Inch Series Button Head Socket Cap Screws (continued)

Standard Screw Length Increments

<u>Nominal Screw Length</u>	<u>Standard Length Increment</u>
1/8 through 1/4	1/16
1/4 through 1 inch	1/8
1 through 2 inches long	1/4

Length Tolerances

<u>Nominal Screw Size</u>	<u>#2 through 3/8</u>	<u>1/2 and 5/8</u>
<u>Nominal Length</u>	<u>Tolerance on Length</u>	
#2 through 1 inch	-0.03	-0.03
Over 1 through 2 1/2 inch	-0.04	-0.06

Mechanical Properties and Tightening Torques

<u>Nominal Size</u>	<u>Basic Screw Diameter</u>	<u>Tensile Strength Pounds Min.</u>	<u>Shear Strength Thread Section Pounds Min.</u>	<u>Tightening Torque Inch Pounds</u>
#4	0.1120	880	620	8
#5	0.1250	--	--	--
#6	0.1380	1320	940	15
#8	0.1640	2030	1450	30
#10	0.1900	2540	1810	65
1/4	0.2500	4610	3300	125
5/16	0.3125	7600	5430	200
3/8	0.3750	11200	8040	360
7/16	0.4375	15400	11000	600
1/2	0.5000	20600	14700	1200
5/8	0.6250	30500	23400	2000
3/4	0.7500	49500	34600	4000
7/8	0.8750	62400	47900	6000
1	1.0000	81800	62850	8500

