

Inch Series Socket Head Shoulder Screws

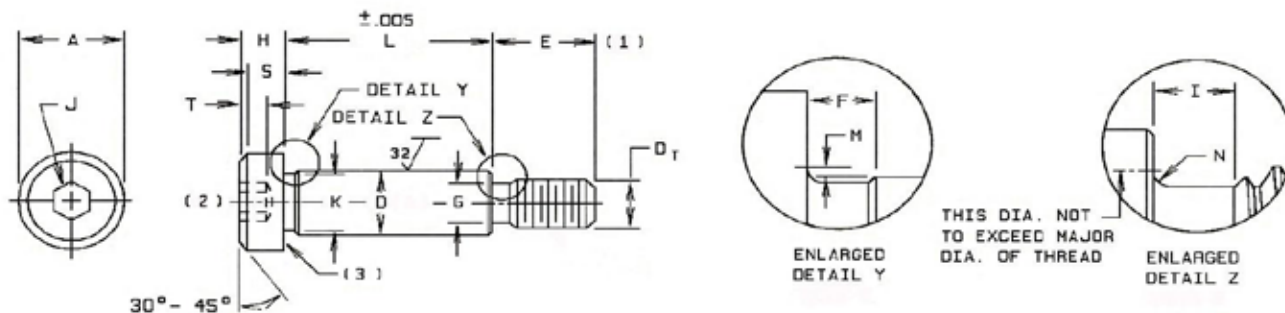

Nominal Shoulder Diameter	D(1) Shoulder Diameter		A Head Diameter		H Head Side Height		S Head Height	J Hex Socket Size	T Key Engagement	E(3) Thread Length
	Max.	Min.	Max.	Min.	Max.	Min.	Min.	Nominal	Min.	Basic
1/4	0.2480	0.2460	0.375	0.357	0.188	0.177	0.157	1/8	0.094	0.375
5/16	0.3105	0.3085	0.438	0.419	0.219	0.209	0.183	5/32	0.117	0.438
3/8	0.3730	0.3710	0.562	0.543	0.250	0.240	0.209	3/16	0.141	0.500
1/2	0.4980	0.4960	0.750	0.729	0.312	0.302	0.262	1/4	0.188	0.625
5/8	0.6230	0.6210	0.875	0.853	0.375	0.365	0.315	5/16	0.234	0.750
3/4	0.7480	0.7460	1.000	0.977	0.500	0.490	0.421	3/8	0.281	0.875
1	0.9980	0.9960	1.312	1.287	0.625	0.610	0.527	1/2	0.375	1.000
1 1/4	1.2480	1.2460	1.750	1.723	0.750	0.735	0.633	5/8	0.469	1.125
1 1/2	1.4980	1.4960	2.125	2.095	1.000	0.980	0.842	7/8	0.656	1.500
1 3/4	1.7480	1.7460	2.375	2.345	1.125	1.105	0.948	1	0.750	1.750
2	1.9980	1.9960	2.750	2.270	1.250	1.230	1.054	1 1/4	0.937	2.000

Nominal Shoulder Diameter	M Head Fillet Ext. Above D		K Shoulder Neck Diameter	F Shoulder Neck Width	Dt Basic Thread Diameter And Pitch	G Thread Neck Diameter		I Thread Neck Width	N Thread Neck Fillet	
	Max.	Min.	Min.	Max.		Max.	Min.	Max.	Max.	Min.
1/4	0.014	0.009	0.227	0.093	#10-24	0.142	0.133	0.083	0.023	0.017
5/16	0.017	0.012	0.289	0.093	1/4-20	0.193	0.182	0.100	0.028	0.022
3/8	0.020	0.015	0.352	0.093	5/16-18	0.249	0.237	0.111	0.031	0.025
1/2	0.026	0.020	0.477	0.093	3/8-16	0.304	0.291	0.125	0.035	0.029
5/8	0.032	0.024	0.602	0.093	1/2-13	0.414	0.397	0.154	0.042	0.036
3/4	0.039	0.030	0.727	0.093	5/8-11	0.521	0.502	0.182	0.051	0.045
1	0.050	0.040	0.977	0.125	3/4-10	0.638	0.616	0.200	0.055	0.049
1 1/4	0.060	0.050	1.227	0.125	7/8-9	0.750	0.726	0.222	0.062	0.056
1 1/2	0.070	0.060	1.478	0.125	1 1/8-7	0.964	0.934	0.286	0.072	0.066
1 3/4	0.080	0.070	1.728	0.125	1 1/4-7	1.089	1.059	0.286	0.072	0.066
2	0.090	0.080	1.978	0.125	1 1/2-6	1.307	1.277	0.333	0.102	0.096

Applicable Standards: ASME B18.3.

Tensile Strength: 140,000psi min. in the shoulder and thread neck area

Shear Strength: 84,000 psi minimum in the minimum thread neck area.

Hardness: Rc 32-43

Inch Series Socket Shoulder Screws (continued)

Notes:

1. **Thread Length Tolerance:** -0.020 in. for sizes up to 3/8 in., inclusive, and -0.030 for sizes over 3/8 inch.
2. **Concentricity:** Head shall be concentric with the shoulder within 1 percent (2 percent total runout) of the nominal diameter D or 0.003 inch (0.006 inch total runout), whichever is greater. Concentricity, parallelism, bow and squareness of shoulder to thread shall be within 0.005 inch total runout per inch of shoulder length, with a maximum of 0.025 inch, when firmly seated against the shoulder in a threaded bushing, and checked on the shoulder a distance of 2F from the underside of the head. Threads of bushing shall be basic size, and bushing OD and ends shall be concentric and square with the axis.
3. **Bearing surface:** The plane of the bearing surface of the head shall be perpendicular to the axis of the shoulder within a maximum deviation of 2 degrees.

Standard Lengths

Nominal Shoulder (Screw) Length	Standard Length Increment
1/4 through 3/4	1/8
3/4 through 5	1/4
Over 5	1/2

Mechanical Properties and Tightening Torques

Nominal Shoulder Diameter	Nominal Thread Size	Tensile Strength Thread Neck Pounds Min.	Single Shear Strength Thread Neck Pounds Min.	Hex Key Size	Tightening Torque Inch-Pounds
1/4	10-24	1945	1166	1/8	50
5/16	1/4-20	3642	2185	5/32	125
3/8	5/16-18	6176	3706	3/16	265
1/2	3/8-16	9311	5587	1/4	470
5/8	1/2-13	17330	10398	5/16	1150
3/4	5/8-11	27709	16625	3/8	2000
1	3/4-10	41723	25033	1/2	4000